

Extraction CEMS – Overview

An extraction Continuous Emissions Monitoring System is in simple terms a device for constantly measuring exhaust gases in a stack or duct, for the purposes of tracking and reporting specific constituents to the EPA.

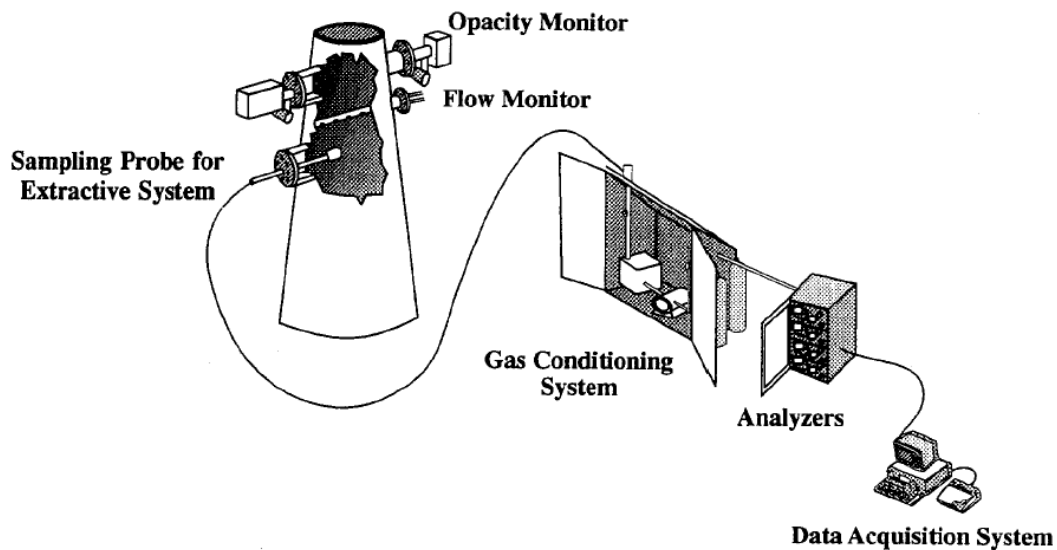

In an extraction system, a sample is drawn (extracted) from the stack by a pump and sent to analyzers for measurement of specific gases.

The information from the analyzers is sent to a Data Acquisition System (or DAS) where it is tracked and recorded. The DAS allows a user to create reports in the specific formats required by the EPA and other local and/or state regulatory agencies.

The extraction system can be broken down into several main components:

- Probe
- Umbilical
- Sample Conditioner
- Analyzers
- Sample/Cal Gas Control System
- DAS

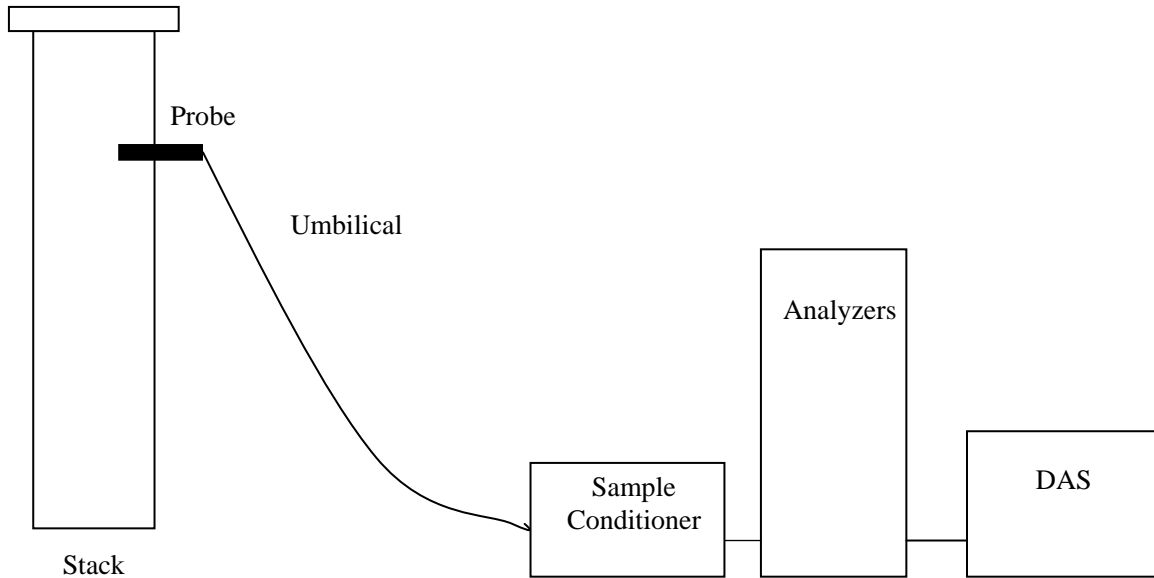

The Probe:

The extraction probe is heated to keep the sample at temperatures between 350-350°F. This eliminates any condensation and formation of acid gases in the probe.

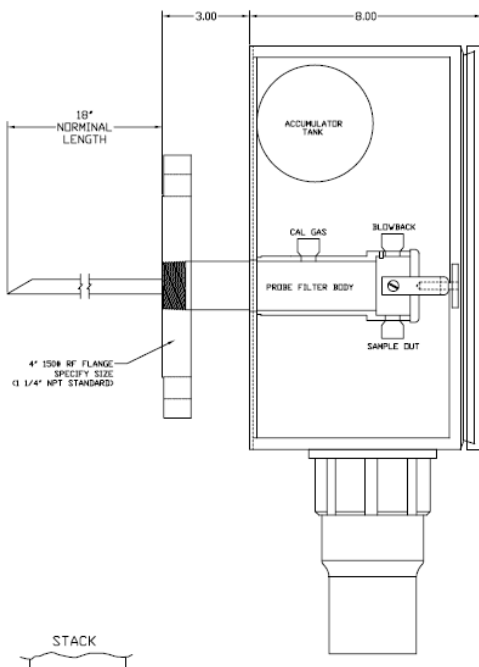

The probe has a 10 micron sintered Stainless Steel replaceable particulate filter.

There are two ports in the probe – one for introduction of cal gas, and one for purge.

Cal gas is introduced before the filter. This allows the “entire” CEM System to be calibrated as the gas follows the same entire path as the stack gas. This is per EPA requirements.

Purging is done with instrument air and is activated by the DAS at user selectable intervals. Air is sent up to the probe until a positive pressure is produced that “blows” out dirt and particulate. The “dirtier” the stack or application, the more frequent a user can set the purge cycle. This keeps the probe cleaner and allows for longer times between maintenance.

The Umbilical:

The umbilical transports the sample from the probe to the analyzer cabinet. It can be up to several hundred feet long as it runs from the top of the stack to the bottom where the analyzer cabinet is installed.

The umbilical in an extraction system, like the probe, is heated to 350-400°F to keep the sample from condensing.

The umbilical serves many functions:

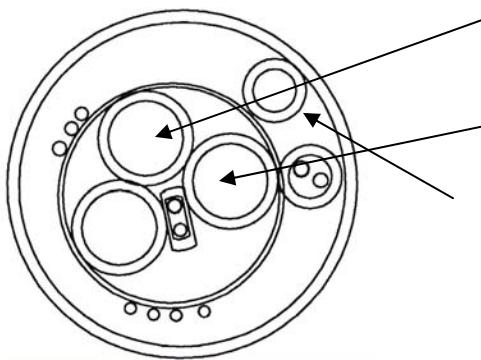

1. Carries the sample from the stack to the analyzer cabinet (heated – 3/8” Teflon, often a spare tube is included)
2. Carries the cal gas up to the probe (heated – 3/8” poly)
3. Carries the purge air up to the probe (1/4” Teflon)
4. Carries the power wiring for the probe heater

Umbilical cross-section:

The Sample Conditioner:

Before the sample can be put through the various gas analyzers, it must first be filtered and cooled to remove moisture. Thermo-Electric Dryers are used for this. They typically reside in or on the floor next to the analyzer cabinet.

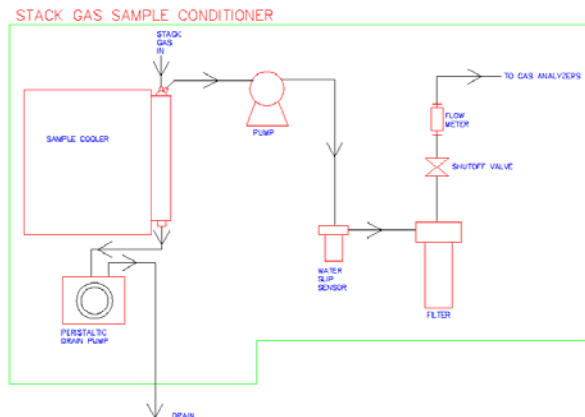

Thermo-Electric dryers cool the sample down through a heat exchanger and draw out the moisture in the saturated sample as it condenses, with a peristaltic pump. The sample is then dry and ready for the analyzers.

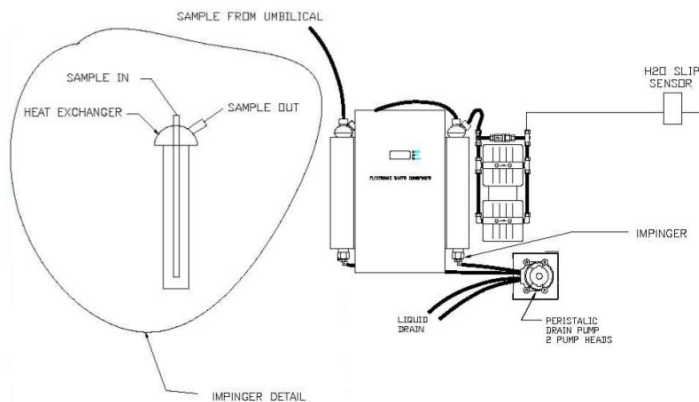

The Analyzers:

Different analyzers are used depending on the type of gases being monitored. This is because each gas is best measured with a unique methodology – i.e. Chemiluminescence for NO_x, pulsed fluorescence for SO₂, zirconia for O₂, etc. The different technologies insure the lowest concentration measurement for each gas can be attained.

A number of analyzers are available to measure a variety of gases including: SO₂, NO_x, CO, CO₂, THC, NH₃ and O₂. The analyzers are mounted in a rack and normally housed in an enclosure for protection from high or low ambient temperatures and severe weather:



NEMA 1 racks: these are used when the analyzer cabinet will reside in a control room type environment where the temperature and humidity are constantly controlled (typically 68-70°F).

NEMA 12 Cabinets: these are typically used indoors, in areas where the temperature is not constantly controlled (i.e. turbine deck). They have built in HVAC units to keep the inside of the cabinet at a constant temperature.



Walk-in Enclosures/Shelters: utilized for outdoor placement of the CEMS equipment. They have their own HVAC for temperature control, and allow maintenance people to work on the units out of the weather.

A calibration gas system is required to perform the daily and quarterly calibrations required by Federal EPA regulations. The system is completely automated and introduces the correct cal gas at appointed times and durations using solenoids that are part of a complete sample/cal control panel. This panel is found in the CEMS rack and is controlled by a PLC.

Beside the analyzers and sample/cal control panel, the CEMS cabinet also typically holds the sample conditioner and pump, heater controllers, and the PLC controller.



- Heater controller
- Sample/Cal control panel
- PLC with Operator Interface Terminal
- Analyzer
- Analyzer
- Sample Conditioner and Pump (behind cover)

Data Acquisition System:

Last but not least is the DAS. The DAS performs many functions:

- Controls the CEMS calibration check and purge cycles
- Monitors the system for trouble (sample conditioning system failure, monitor faults, etc.)
- Outputs alarms in the event of system faults or emission exceedances
- Collects and stores the data
- Generates reports for EPA

The DAS is made up of two parts – the PLC and the PC.

A PLC is used as the main controller and interface between the CEMS and the DAS computer. It is usually located in the analyzer cabinet. It is comprised of analog inputs and outputs and digital inputs and outputs. Some examples:



- Analog Inputs: the analyzer signals, fuel flow signals, process signals, etc.
- Analog Outputs: retransmission of analyzer signals (gas values) to a plant PLC (can also be accomplished via an Ethernet connection)
- Digital Inputs: process signals (ID fan on/off for example), alarm contacts from sample conditioner, analyzers, etc.
- Digital Outputs: alarm contact to plant PLC (can also be accomplished via an Ethernet connection), calibration solenoid enabling, purge solenoid enabling, etc.

DAS Computer:

The DAS computer is connected directly to the PLC and receives all the information for storage, calculations and reporting. The DAS computer can sometimes be found in a CEMS shelter next to the analyzer cabinet, but often it is located remotely in a control room.



The DAS computer maintains and displays the status of the CEMS for an operator:

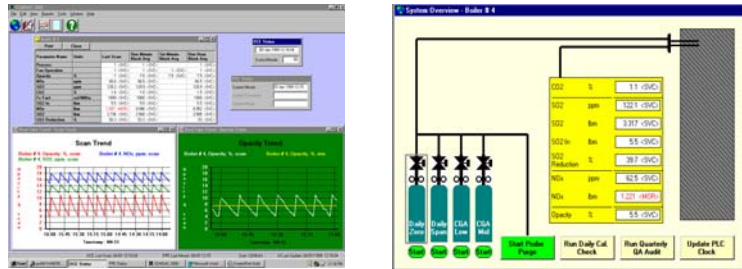

It alerts the user of alarm conditions:

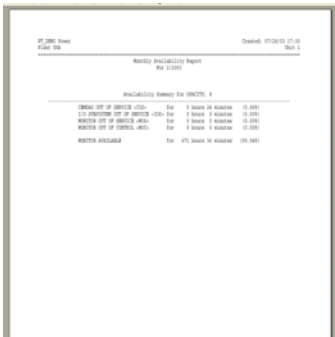
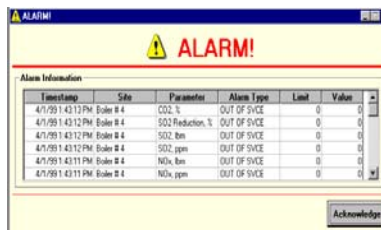

and allows for reports to be generated (both manually and automatically) from the stored data:

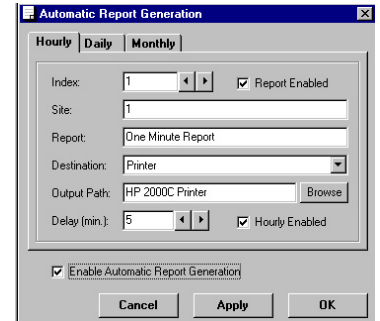

Extraction CEMS are designed with high reliability, ease of use and ease of maintenance in mind. They are built for easy upgrades in the future and are the system of choice where low pollutant levels are found and accurate measurement is desired.